

State-Variable Technique

Motivation of State-Variable Techniques: How to simulate an implementation?

The transfer function (in both s- and z-domain) and the time convolution with impulse response allow us to compute the output for any input signal. However, both approaches do not govern a particular *implementation* of the system.

For example, in chapter 8, we have described a number of implementations such as direct form I, direct form II, parallel form and cascade form for a discrete-system such as follows:

$$H(z) = \frac{1 + z^{-1}}{1 - \frac{1}{3}z^{-1}}$$

Example of implementations:

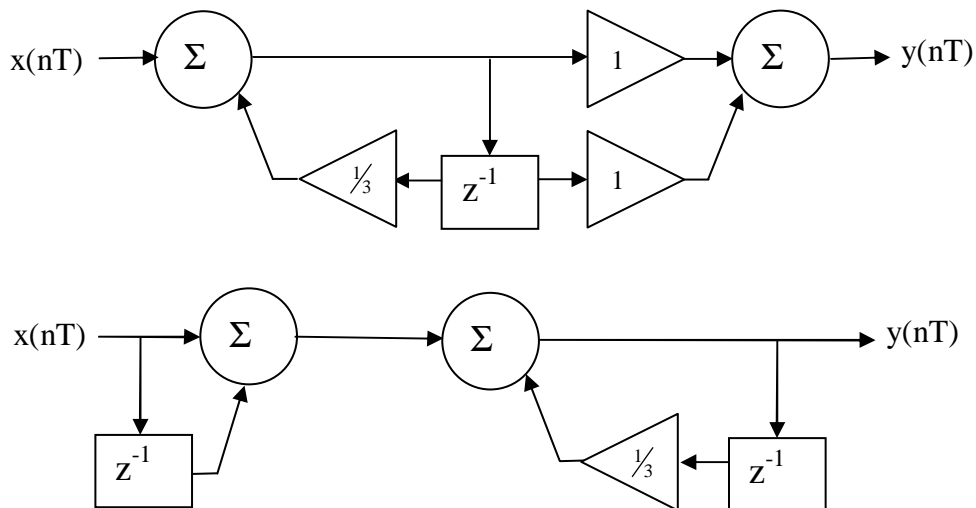

There are in fact infinite number of implementations for this transfer function because we can arbitrary add factors

$$H(z) = \frac{1 + z^{-1}}{1 - \frac{1}{3}z^{-1}} \cdot \frac{1 - cz^{-1}}{1 - cz^{-1}}$$

$$e.g. \quad c = \frac{1}{3} \Rightarrow H(z) = \frac{1 + \frac{2}{3}z^{-1} - \frac{1}{3}z^{-2}}{1 - \frac{2}{3}z^{-1} + \frac{1}{9}z^{-2}}$$

Another implementation:

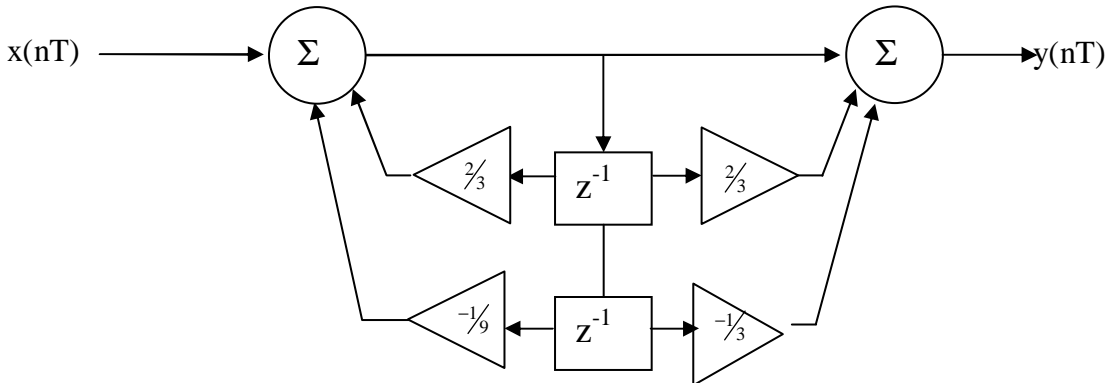

To characterize each implementation, it is essential to keep track of the “internal state” of the system, which are the current value at each register (remember the state diagram in your digital logic design class?)

It is important to have a implementation-based representation that allows us to

1. examine any signal within the implementation (for possible instability within the implementation);
2. identify if any part of the implementation is redundant, and
3. determine how “observable” (whether we can infer the internal state of the system based on outputs) and “controllable” (whether we can steer the internal state to a desirable configuration using input) the system is.

These topics will be the focus of EE 571 (Feedback Control Design) and EE 572 (Discrete Control Design). In this course, we will introduce the main tool used in the design: the state-space representation. In addition, we will focus on the continuous-time version of the state-space representation.

“Big picture”

One can convert between three different representations which serve different purposes:

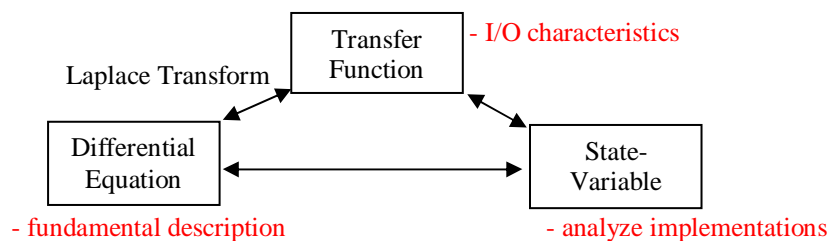

Brief Review of Matrix Algebra

The most fundamental concept in linear algebra is matrix.

Matrix is a rectangular array of numbers: $A = \begin{pmatrix} 1 & 2 \\ 3 & 4 \end{pmatrix}$ $B = \begin{pmatrix} -1.2 & 3 \\ 2 & 4.4 \\ 3+4i & 23 \end{pmatrix}$

Matrices are described by its number of rows and columns. When describing a matrix, we need to describe the number of rows first before columns. So, A is a “2 by 2 matrix” and B is a “3 by 2 matrix”.

We can add and subtract matrices of the *same dimensions* only:

Example: $\begin{pmatrix} 1 & 2 \\ 3 & 5 \end{pmatrix} + \begin{pmatrix} -1 & 0 \\ 0 & 3 \end{pmatrix} = \begin{pmatrix} 0 & 2 \\ 3 & 8 \end{pmatrix}$

Matrix multiplication can only be applied to matrices if *the number of columns in the first matrix matches the number of rows*:

Example: $\begin{pmatrix} 2 & 3 \\ 1 & 4 \\ -1 & 1 \end{pmatrix} \cdot \begin{pmatrix} 1 & 2 & 3 \\ 4 & 5 & 6 \end{pmatrix} = \begin{pmatrix} 2 \cdot 1 + 3 \cdot 4 & 2 \cdot 2 + 3 \cdot 5 & 2 \cdot 3 + 3 \cdot 6 \\ 1 \cdot 1 + 4 \cdot 4 & 1 \cdot 2 + 4 \cdot 5 & 1 \cdot 3 + 4 \cdot 6 \\ -1 \cdot 1 + 1 \cdot 4 & -1 \cdot 2 + 1 \cdot 5 & -1 \cdot 3 + 1 \cdot 6 \end{pmatrix} = \begin{pmatrix} 14 & 19 & 24 \\ 15 & 22 & 27 \\ 3 & 3 & 3 \end{pmatrix}$

In other words, the entry at the *i*-th row and *j*-th column of the resulting matrix is *the inner product of the i-th row vector of the first matrix and the j-th column vector of the second matrix*.

Important: Matrix multiplication is not commutative.

$$\begin{pmatrix} 2 & 3 \\ 1 & 4 \\ -1 & 1 \end{pmatrix} \cdot \begin{pmatrix} 1 & 2 & 3 \\ 4 & 5 & 6 \end{pmatrix} \neq \begin{pmatrix} 1 & 2 & 3 \\ 4 & 5 & 6 \end{pmatrix} \cdot \begin{pmatrix} 2 & 3 \\ 1 & 4 \\ -1 & 1 \end{pmatrix} \text{ The right side is not even a matrix product!}$$

Does not work even for square matrices:

$$\begin{pmatrix} a & b \\ c & d \end{pmatrix} \cdot \begin{pmatrix} e & f \\ g & h \end{pmatrix} = \begin{pmatrix} ae + bg & af + bh \\ ce + dg & cf + dh \end{pmatrix}$$

$$\begin{pmatrix} e & f \\ g & h \end{pmatrix} \cdot \begin{pmatrix} a & b \\ c & d \end{pmatrix} = \begin{pmatrix} ea + fc & eb + fd \\ ga + hc & gb + hd \end{pmatrix}$$

Division in matrix algebra is represented via matrix inverse.

$$A \cdot B = C \Rightarrow B = A^{-1} \cdot C$$

We need to be careful when handling matrix inverse because

- a. Only square matrix has inverse – this is because inverse matrix represents an inverse linear transform, which is only feasible if the input and output dimensions are the same.
- b. Not all square matrix has inverse – a simple test:

$$A^{-1} \text{ exists } \Leftrightarrow \det(A) \neq 0$$

$\det(A)$ denotes the determinant of a matrix and it is a real number. If A is 2×2 , $\det(A)$ measures the area of the parallelogram formed by the two column vectors. If A is 3×3 , $\det(A)$ measures the volume of the polyhedron formed by the three column vectors. For 2×2 matrix:

$$\det \begin{bmatrix} a & b \\ c & d \end{bmatrix} \equiv \begin{vmatrix} a & b \\ c & d \end{vmatrix} \equiv ad - bc.$$

Higher dimension determinant can be computed recursively:

$$\begin{vmatrix} a_{11} & a_{12} & a_{13} & \dots & a_{1k} \\ a_{21} & a_{22} & a_{23} & \dots & a_{2k} \\ \vdots & \vdots & \vdots & \ddots & \vdots \\ a_{k1} & a_{k2} & a_{k3} & \dots & a_{kk} \end{vmatrix} = a_{11} \begin{vmatrix} a_{22} & a_{23} & \dots & a_{2k} \\ \vdots & \vdots & \ddots & \vdots \\ a_{k2} & a_{k3} & \dots & a_{kk} \end{vmatrix} - a_{12} \begin{vmatrix} a_{21} & a_{23} & \dots & a_{2k} \\ \vdots & \vdots & \ddots & \vdots \\ a_{k1} & a_{k3} & \dots & a_{kk} \end{vmatrix} + \dots \pm a_{1k} \begin{vmatrix} a_{21} & a_{22} & \dots & a_{2(k-1)} \\ \vdots & \vdots & \ddots & \vdots \\ a_{k1} & a_{k2} & \dots & a_{k(k-1)} \end{vmatrix}.$$

Or more compactly, $\det(\mathbf{A}) = \sum_{j=1}^k a_{1j} C_{1j}$ where $C_{ij} = (-1)^{i+j} \det(\mathbf{M}_{ij})$ is called the i - j^{th} *co-factor* and \mathbf{M}_{ij} is called a *minor*, which is defined a matrix formed by deleting the i -th row and j -th column from \mathbf{A} .

Example: $\det \begin{bmatrix} -1 & 5 & 2 \\ 3 & 4 & 1 \\ 1 & 2 & 2 \end{bmatrix} = -1 \cdot \begin{vmatrix} 4 & 1 \\ 2 & 2 \end{vmatrix} - 5 \cdot \begin{vmatrix} 3 & 1 \\ 1 & 2 \end{vmatrix} + 2 \cdot \begin{vmatrix} 3 & 4 \\ 1 & 2 \end{vmatrix} = -1 \cdot 6 - 5 \cdot 5 + 2 \cdot 2 = -27$

Using the knowledge of determinant, we can numerically compute the matrix inverse.

For 2×2 matrix $\mathbf{A} = \begin{pmatrix} a & b \\ c & d \end{pmatrix}$, its inverse can be computed as

$$\mathbf{A}^{-1} = \frac{1}{ad - bc} \begin{pmatrix} d & -b \\ -c & a \end{pmatrix}$$

For general matrix, $\mathbf{A}^{-1} = \frac{1}{\det(\mathbf{A})} \begin{pmatrix} C_{11} & \dots & C_{1n} \\ \vdots & & \vdots \\ C_{n1} & \dots & C_{nn} \end{pmatrix}^T$ where C_{ij} is the i - j^{th} co-factor.